



**BEST TECH**  
MACHINE



ติดต่อฝ่ายขาย

+66(0)99 419 2355



chutikarn@besttechmachine.com  
sales.besttechmachine@gmail.com

**BEST TECH MACHINE CO., LTD. / บริษัท เบท เทค แมชชีน จำกัด**

146/19 หมู่บ้านเพชรดา 3 หมู่ 5 ตำบลแพรกษาใหม่ อำเภอเมือง จังหวัดสมุทรปราการ 10280  
146/19 Phetlada 3, Moo 5, Praek Sa Mai, Mueang Samutprakarn,  
Samutprakarn 10280

TAX : 0115566001512



# VARIOUS SAMPLES OF LIQUID AND PASTE FILLING MACHINE



| Model       | Output(BPM) |       |       |       |
|-------------|-------------|-------|-------|-------|
|             | Y1WTD       | Y2WTD | G1WTD | G2WTD |
| 10-100ml    | 12-25       | 24-50 | 10-20 | 20-40 |
| 30-300ml    | 8-25        | 16-50 | 8-20  | 16-40 |
| 50-500ml    | 7-25        | 14-50 | 7-20  | 14-40 |
| 100-1000ml  | 5-20        | 10-40 | 5-12  | 10-24 |
| 500-2500ml  | 2-8         | 4-16  | 3-8   | 6-16  |
| 1000-5000ml | 2-8         | 4-16  | 2-8   | 4-16  |

## Filling Range

10-100ml/30-300ml/50-500ml/100-1000ml/500-2500ml/1000-5000ml

### ONE HEAD LIQUID FILLER

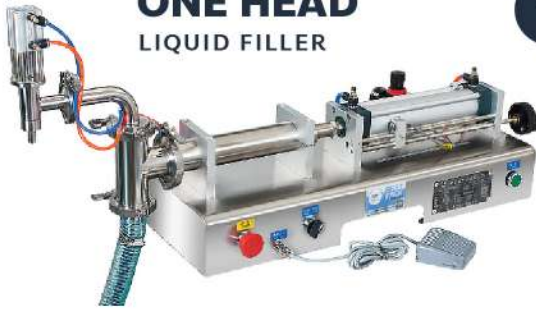

### Y1WTD SERIES ONE HEAD LIQUID FILLER

Model : **Y1WTD-1000**  
Power : **15W**

Filling Accuracy : **<±1 % (Decide by product)**

Working Air Pressure : **0.4-0.6MPa**  
Weight : **23KG**  
Packing size : **91\*31\*32cm**

### Y2WTD SERIES DOUBLE HEADS LIQUID FILLER

Model : **Y2WTD-1000**  
Power : **30W**

Filling Accuracy : **<±1 % (Decide by product)**

Working Air Pressure : **0.4-0.6MPa**  
Weight : **42KG**  
Packing size : **91\*42\*32cm**

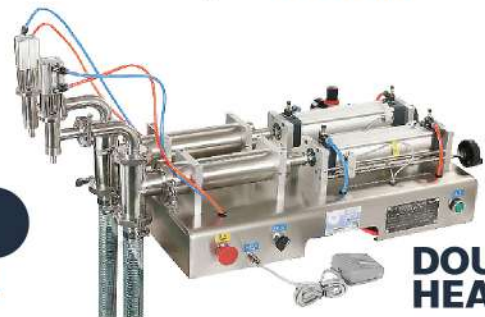

### DOUBLE HEADS LIQUID FILLER

### G1WTD SERIES ONE HEAD PASTE FILLER

Model : **G1WTD-1000**  
Power : **15W**

Filling Accuracy : **<±1 % (Decide by product)**

Working Air Pressure : **0.4-0.6MPa**  
Weight : **31KG**  
Hopper Size : **45\*45\*45cm**  
Packing size : **105\*32\*33cm**



### ONE HEAD PASTE FILLER



### DOUBLE HEADS PASTE FILLER

### G2WTD SERIES DOUBLE HEADS PASTE FILLER

Model : **G2WTD-1000**  
Power : **30W**

Filling Accuracy : **<±1 % (Decide by product)**

Working Air Pressure : **0.4-0.6MPa**  
Weight : **49KG**  
Hopper Size : **45\*45\*45cm**  
Packing size : **106\*45\*30cm**

# VARIOUS SAMPLES OF LIQUID AND PASTE FILLING MACHINE

## Filling Range

10-100ml/30-300ml/50-500ml/100-1000ml/500-2500ml/1000-5000ml



**G1WTD-1000H**  
**ONE HEAD**  
HOPPER HEATING  
FUNCTION

### G1WTD SERIES

ONE HEAD  
HOPPER HEATING  
FUNCTION

Model : **G1WTD-1000H**  
Power : **150W**

Filling Accuracy :  
**<±1%(Decide by product)**

Working Air Pressure : **0.4-0.6MPa**  
Weight : **49KG**  
Packing Size : **58\*49\*71cm**  
Hoppers Size : **105\*31\*33cm**

Hopper  
with Mixer



### G1WTD SERIES

ONE HEAD  
STIRRING FUNCTION

Model : **G1WTD-1000M**  
Power : **2000W**

Filling Accuracy :  
**<±1%(Decide by product)**

Working Air Pressure : **0.4-0.6MPa**  
Weight : **46KG**  
Packing Size : **46.5\*46.6\*76cm**  
Hoppers Size : **105\*32\*33cm**



**G1WTD-1000M**  
**ONE HEAD**  
STIRRING FUNCTION



**G1WTD-1000HM**  
**ONE HEAD**  
HEATER AND MIXER

### G1WTD SERIES

ONE HEAD  
HEATER AND MIXER

Model : **G1WTD-1000HM**  
Power : **2150W**

Filling Accuracy :  
**<±1%(Decide by product)**

Working Air Pressure : **0.4-0.6MPa**  
Weight : **55KG**  
Hopper Size : **58\*54\*85cm**  
Packing size : **105\*32\*33cm**

## Filling Range

10-100ml/30-300ml/150-500ml/100-1000ml/1500-2500ml/1000-5000ml



### G1WTD SERIES

HORIZONTAL MIXING FUNCTION

Filling Accuracy :  
**<±1%(Decide by product)**

Model : **G1WTD-1000W** Power : **280W**

Working Air Pressure : **0.4-0.6MPa**  
Weight : **60KG**  
Hopper Size : **54\*54\*47cm**  
Packing size : **104\*45\*75cm**



# VACUUM PACKING MACHINE



## DZ-T300 BRICK SHAPE VACUUM PACKING MACHINE

Model : **DZ-T300**  
Sealing Size (mm) : **300x5 mm.**

Packing Size (mm) : **470Lx410Wx440H**  
Chamber Size (mm) : **335Lx140Wx245H**

Rice brick



## LARGE CHAMBER VACUUM PACKING MACHINE

### DZ-350

Model : **DZ-350**  
Sealing Size (mm) : **350x10 mm.**  
Packing Size (mm) : **650Lx520Wx400H**  
Chamber Size (mm) : **370Lx450Wx170H**

### DZ-450

Model : **DZ-450**  
Sealing Size (mm) : **450x10 mm.**  
Packing Size (mm) : **650Lx620Wx600H**  
Chamber Size (mm) : **460Lx450Wx170H**



## TABLE TOP VACUUM PACKING MACHINE

### DZ-400T

Model : **DZ-400T**  
Sealing Size (mm) : **400x10 mm.**  
Packing Size (mm) : **650Lx590Wx600H**  
Chamber Size (mm) : **420Lx420Wx70H**

### DZ-500T

Model : **DZ-500T**  
Sealing Size (mm) : **500x10 mm.**  
Packing Size (mm) : **760Lx690Wx680H**  
Chamber Size (mm) : **520Lx520Wx70H**

## STAND TYPE VACUUM PACKING MACHINE DZ-400/DZ-500/DZ-600

Model : **DZ-400**  
Sealing Size (mm) : **400x10 mm.**  
Chamber Size (mm) : **420Lx440Wx70H**  
Packing Size (mm) : **650Lx590Wx1000H**

Model : **DZ-500**  
Sealing Size (mm) : **500x10 mm.**  
Chamber Size (mm) : **520Lx520Wx70H**  
Packing Size (mm) : **760Lx690Wx1080H**

Model : **DZ-600**  
Sealing Size (mm) : **600x10 mm.**  
Chamber Size (mm) : **630Lx630Wx100H**  
Packing Size (mm) : **870Lx850Wx1100H**

## STAND TYPE VACUUM PACKING MACHINE DZ-400/DZ-500/DZ-600

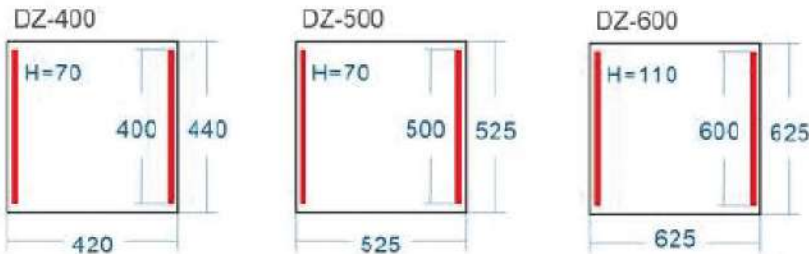

# CONTINUOUS SEALING MACHINE

Stainless steel

## FR-880LW / AUTOMATIC SEALING MACHIN



Paint



Motor power: **80 W.**  
Voltage : **110V/220V**  
Temp. Range : **0-300 °C**  
Film thickness : **<0.8 mm.**  
Sealing width : **6-12 mm.**  
Sealing speed : **≤19 m/min**  
Weight : **22KG**  
Packing size : **88x44x36 cm.**

## DBF-1000G / AUTO BAG SEALER WITH AIR INFLATION



Motor power: **80 W.**  
Voltage : **110V/220V**  
Temp. Range : **0-300 °C**  
Film thickness : **<0.8 mm.**  
Sealing width : **6-12 mm.**  
Sealing speed : **≤12 m/min**  
Weight : **50KG**  
Packing size : **102x59x99 cm.**

## LF-1080

AUTO BAG SEALING MACHINE  
(VACUUM/GAS INFLATION)

Motor power: **50 W.**  
Voltage : **110V/220V**  
Temp. Range : **0-300 °C**  
Film thickness : **<0.8 mm.**  
Sealing width : **6-12 mm.**  
Sealing speed : **≤12 m/min**  
Weight : **84KG**  
Packing size : **113x59x103 cm.**



## XK-1100V

VERTICAL TYPE  
(SEALING HEIGHT ADJUSTABLE)



Motor power: **120 W.**  
Voltage : **110V/220V**  
Temp. Range : **0-300 °C**  
Film thickness : **<0.8 mm.**  
Sealing width : **6-12 mm.**  
Sealing speed : **≤12 m/min**  
Weight : **163KG**  
Packing size : **150x147x67 cm.**

## XK-1100V

VERTICAL TYPE  
(SEALING HEIGHT ADJUSTABLE)

Motor power: **120 W.**  
Voltage : **110V/220V**  
Temp. Range : **0-300 °C**  
Film thickness : **<0.8 mm.**  
Sealing width : **6-12 mm.**  
Sealing speed : **≤12 m/min**  
Weight : **130KG**  
Packing size : **128x66x124 cm.**



# HIGH SPEED ROTARY FILL-SEAL MACHINE



## FEATURES AND CHARACTERISTICS

1. MR8-200RWF automatic rotary packing machine can dispense, open and close pre-made pouch with other packing equipments.
2. Safety guard can ensure the machine with high speed and consistent production.
3. Good quality components are selected for machine's durability.
4. The machine is versatile in design part, it is easily linked up with other packing equipments, such as liquid filler, powder filler, check weigher, case sealer etc.



**APPLICATION** Milk Powder, Coffee Powder, Food additive contents  
**Powder Species:** Mik powdet, cottee powdet Food addiaves condinents, Tapioca powdet, Coconut powder, Pesticide powder, Fertilzer Granules etc.  
 Powder

## THE MAIN TECHNICAL PARAMETERS

| Model                    | MRB-200RWF  |
|--------------------------|---|
| Bag size                 | W:80-210 mm. L: 100-300 mm.   |
| Filling Volume           | 5 - 2500g (Depending on type of products)   |
| Capacity                 | 25-60 bags/min (The speed depends on type of products and packaging matetial used)  |
| Accuracy                 | Error $\leq$ 1 %  |
| Total power consurrption | 3.60W / Automatic Auger Filler  |
| Dosing Assembly          |   |
| Pouch Type               | All type of heat sealable preformed side seal bags, gusseted bags block bottor bags, Ip-lock recloseable bags, stand-up pouch with or without spo |

## STANDARD ACCESSORIES

1. Hat Fall Date Coder
2. PLC Controler
3. Pouch Dpen Guide With Open Detector
4. Dosing Chute But Exdude Ailling Machine
5. Pneurnatic Cylinders
6. Temnperature Controller
7. Pneurnatic Vavves
8. Vacuum Purrrp
9. Frequency Comwerter
10. Discharge Comeyor

## BAG TYPE :

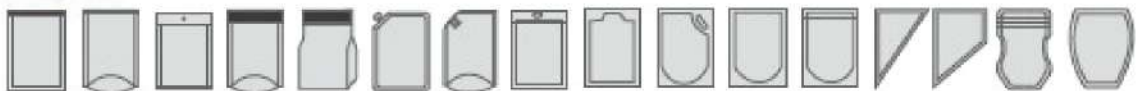

## PRODUCTION PROCESS :

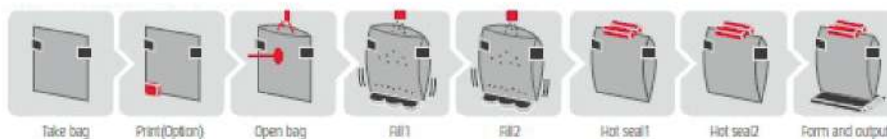

## DRAWING :

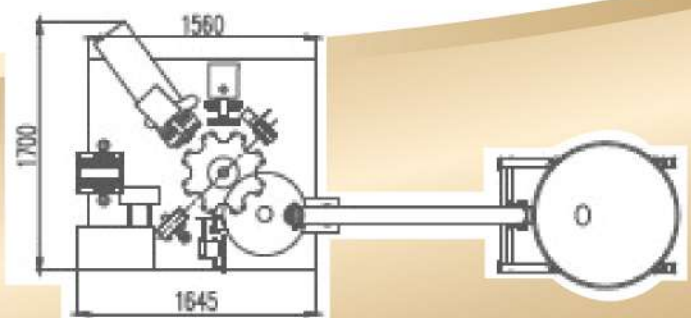
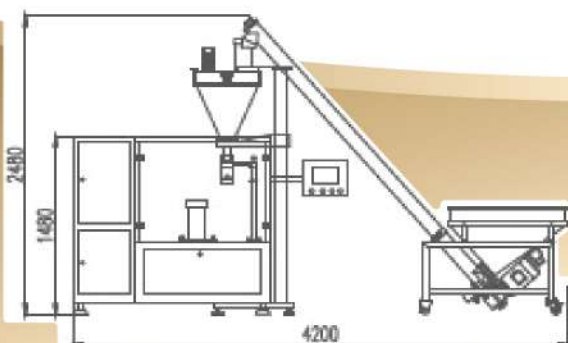

# SOLID & GRANULE PACKAGING PRODUCTION LINE



## FEATURES AND CHARACTERISTICS

1. MR8-200RWG automatic rotary packing machine can dispense, open and close pre-made pouch with other packing equipments.
2. Safety guard can ensure the machine with high speed and consistent production.
3. Good quality components are selected for machine's durability.
4. The machine is versatile in design part, it is easily linked up with other packing equipments, such as liquid filler, powder filler, multi-heads weigher and checking weigher, case sealer etc.

## APPLICATION

**Solid:** candy, peanut, green bean, pistachio, brown sugar, cake, daily commodities, cooked food, pickles, puffed food etc.

**Granule:** grain, granular drug, capsule, seed, condiment, granulated sugar, Chicken essence, melon seeds, nuts etc.

## BAG TYPE

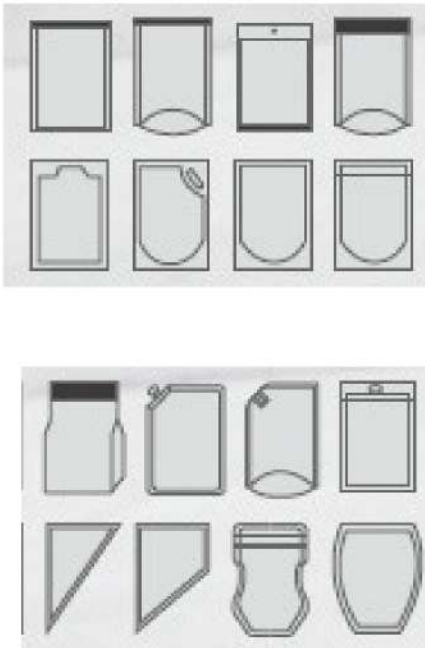

## PRODUCTION PROCESS



# EC-420/520/720

Automatic Vertical Packing Machine

## FEATURES AND CHARACTERISTICS

1. English and Chinese screen display ,operation is simple .
2. It can stock ten dispose , simple to change variety.
3. Servo motor drawing film , position accurately.
4. PLC computer system, the function is more stable, adjusting any parameters don't need to stop machine.
5. Independent temperature control system , precision get to  $\pm 1\%$ .
6. Horizontal , vertical temperature control ,suitable for various of mix film , PE film packing material.
7. Packing type diversification , pillow sealing, standing type, punching etc.
8. Bag-making, sealing, packing , printing date in one operation.
9. Work circumstance quiet, low noise.



VFFS MACHINE

# DXD-300/420/630

Full Automatic Pillow Type Packing Machine

## FEATURES AND CHARACTERISTICS

1. All use the servo intelligentized control, run with low noise, make comfortable environment.
2. Feeding, forming, filling and sealing the whole process is automatic, can carry through the pipelining directly, have high automatic operation.
3. Design with the humanoid, uses the industry's touch screen, intuitionistic shows parameter, man-machine overlapping exchange way operation, menu operation, easy to operate.
4. The horizontal sealing and film is synchronization, the sealing is more reliable and artistic.
5. The length adjustment scope is extremely broad, suitable for packing many kinds of products.



### Model DXD-300

|                     |   |                                |                                |
|---------------------|---|--------------------------------|--------------------------------|
| Bag size            | L: 170-400mm<br>W: 35-100mm<br>H: 20-60mm | 80-300mm<br>35-100mm<br>3-40mm | 60-100mm<br>35-100mm<br>2-30mm |
| Production capacity | 30-140ppm<br>(single jaw)                 | 80-290ppm<br>(Double Jaws)     | 80-29ppm<br>(Double Jaws)      |
| Max. Width of film  | 300mm                                     |                                |                                |
| Max. Dia of film    | Ø350mm                                    |                                |                                |
| Total power         | 3kw(220V 50-60HZ)                         |                                |                                |
| Dimension           | 4700x850x1550mm                           |                                |                                |
| Weight              | 900kg                                     |                                |                                |

### Model DXD-420 DXD-630

|                     |                                   |                                 |                                      |                                    |
|---------------------|-----------------------------------|---------------------------------|--------------------------------------|------------------------------------|
| Bag size            | 190-450mm<br>40-140mm<br>25-110mm | 90-270mm<br>40-140mm<br>25-80mm | 220-450mm<br>120-250mm<br>10-80mm    | 220-450mm<br>120-250mm<br>20-120mm |
| Production capacity | 35-130<br>(bags/mln)              | 60-260<br>(bags/mln)            | 15-80<br>Pcs/mln                     | 15-60<br>Pcs/mln                   |
| Max. Width of film  | 480mm                             |                                 |                                      |                                    |
| Max. Dia of film    | Ø300mm                            |                                 |                                      |                                    |
| Total power         | 3kw(220V 50-60HZ)                 |                                 |                                      |                                    |
| Dimension           | 3500x1000x1500mm                  |                                 | 4000x1250x1500mm<br>4500x1300x1500mm |                                    |
| Weight              | 700kg                             |                                 |                                      |                                    |

## VFFS TECHNICAL PARAMETERS

| Model                               | EC-420                     | EC-520                      | EC-720                      |
|-------------------------------------|----------------------------|-----------------------------|-----------------------------|
| Bag Length                          | 80-300mm                   | 80-400mm                    | 100-400mm                   |
| Bag Width<br>Max width of roll film | 50-200mm<br>420mm          | 80-250mm<br>520mm           | 180-350mm<br>720mm          |
| Packing Speed<br>Measuring range    | 5-60bags/min<br>150-1200ml | 5-50bags/min<br>2000ml(Max) | 5-10bags/min<br>6000ml(Max) |
| Air consumption                     | 0.65Mpa                    | 0.65Mpa                     | 0.65Mpa                     |
| Gas consumption                     | 0.3m <sup>3</sup> /min     | 0.4m <sup>3</sup> /min      | 0.4m <sup>3</sup> /min      |
| Power Voltage                       | 220V/50HZ                  | 220V/50HZ                   | 220V/50HZ                   |
| POWER                               | 2.2KW                      | 4KW                         | 5KW                         |
| Dimension(LxWxH)                    | 1320mm x 950mm x 1360mm    | 1150mm x 1795mm x 1650mm    | 1780mm x 1340 mm x 2100mm   |
| Weight of machine                   | 540Kg                      | 600Kg                       | 900Kg                       |



# PRODUCTS



Case Sealer

Vibration Feeder

Z-Bucket Elevator



Liquid Piston Filling Machine

Bowl Conveyor



Labeling Machine

Vibration Feeder



Single Bucket Elevator

Rotary Cup Feeder



Labeling Machine

Multi-heads weigher



Incline Conveyor

Double Incline Conveyor



ติดต่อฝ่ายขาย

+66(0)99 419 2355



chutikarn@besttechmachine.com  
sales.besttechmachine@gmail.com

**BEST TECH MACHINE CO., LTD. / บริษัท เบท์ เทคโนโลยี แมชชีน จำกัด**

146/19 หมู่บ้านเพชรดา 3 หมู่ 5 ตำบลแพรกษาใหม่ อำเภอเมือง จังหวัดสมุทรปราการ 10280  
146/19 Phetlada 3, Moo 5, Praek Sa Mai, Mueang Samutprakarn,  
Samutprakarn 10280

TAX : 0115566001512

